

CUTTING PLOTTER

CG-60SL
CUTTING PLOTTER

QUICK REFERENCE GUIDE

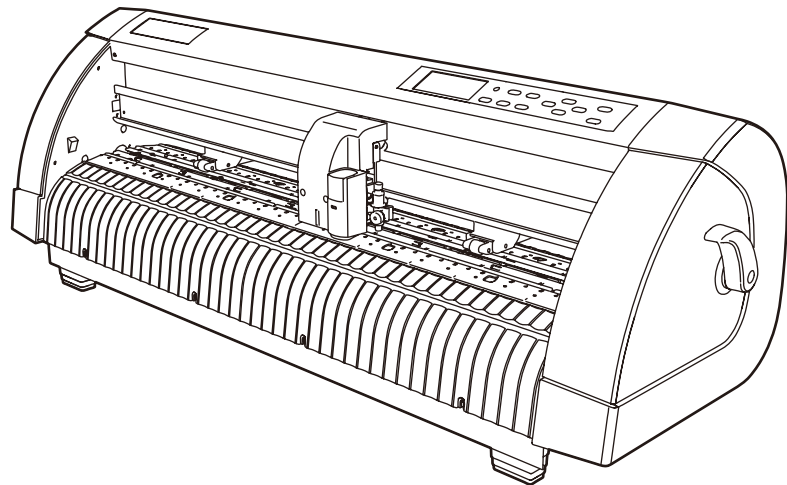

MIMAKI ENGINEERING CO., LTD.

TKB Gotenyama Building, 5-9-41, Kitashinagawa, Shinagawa-ku,
Tokyo 141-0001, Japan

Phone: +81-3-5420-8671 Fax: +81-3-5420-8687

URL: <http://www.mimaki.co.jp/>

D201653-13

TABLE OF CONTENTS

Foreword	3
CAUTION	4
DISCLAIMER OF WARRANTY	4
Requests	4
FCC Statement (USA)	4
Interference to televisions and radios	4
About media	4
Safety Precautions	5
Symbols	5
Safety Labels	7
Checking the accessories	8
Configuration and function	9
The Front	9
The Rear	9
Operation Panel	10
Connecting the cables	11
USB Cable Connection	11
Connecting the power cable	11
Operation flow	12
Installing a tool	13
Using a cutter	13
How to Install a Ballpoint Pen	16
Turning the power on	17
Setting the tool conditions	18
Kinds of the Tool Conditions	18
Set the Tool Conditions.	19
Loading a sheet of media	21
Loading a leaf sheet (cut sheet)	23
How to Place the Roll Sheet	25
Test cutting (plotting)	27

Cutting (plotting)	28
Setting the origin	28
Start cutting (plotting)	29
Turning the power off	30

Foreword

Congratulations on your purchase of Mimaki cutting plotter CG-60SL.
This guide explains basic operation of CG-60SL.
For more details, please refer to the “CG-60SL Operation Manual” supplied with the attached plugin software FineCut CD-ROM.

DISCLAIMER OF WARRANTY

DISCLAIMER OF WARRANTY : THIS LIMITED WARRANTY OF MIMAKI SHALL BE THE SOLE AND EXCLUSIVE WARRANTY AND IS IN LIEU OF ALL OTHER WARRANTIES, EXPRESS OR IMPLIED, INCLUDING, BUT NOT LIMITED TO, ANY IMPLIED WARRANTY OF MERCHANTABILITY OR FITNESS, AND MIMAKI NEITHER ASSUMES NOR AUTHORIZES DEALER TO ASSUME FOR IT ANY OTHER OBLIGATION OR LIABILITY OR MAKE ANY OTHER WARRANTY OR MAKE ANY OTHER WARRANTY IN CONNECTION WITH ANY PRODUCT WITHOUT MIMAKI'S PRIOR WRITTEN CONSENT. IN NO EVENT SHALL MIMAKI BE LIABLE FOR SPECIAL, INCIDENTAL OR CONSEQUENTIAL DAMAGES OR FOR LOSS OF PROFITS OF DEALER OR CUSTOMERS OF ANY PRODUCT.

Requests

- This Operation manual has been carefully prepared for your easy understanding. However, please do not hesitate to contact a distributor in your district or our office if you have any inquiry.
- Description contained in this Operation manual are subject to change without notice for improvement.

FCC Statement (USA)

This equipment has been tested and found to comply with the limits for a Class A digital device, pursuant to Part 15 of the FCC Rules. These limits are designed to provide reasonable protection against harmful interference when the equipment is operated in a commercial environment. This equipment generates, uses and can radiate radio frequency energy and, if not installed and used in accordance with the Operation manual, may cause harmful interference to radio communications. Operation of this equipment in a residential area is likely to cause harmful interference in which case the user will be required to correct the interference at his own expense.



- In the case where MIMAKI-recommended cable is not used for connection of this device, limits provided by FCC rules can be exceeded. To prevent this, use of MIMAKI-recommended cable is essential for the connection of this plotter.

Interference to televisions and radios

The product described in this manual generates high frequency when operating. The product can interfere with radios and televisions if set up or commissioned under improper conditions. The product is not guaranteed against any damage to specific-purpose radio and televisions. The product's interference with your radio or television will be checked by turning on/off the power switch of the product.

In the event that the product is the cause of interference, try to eliminate it by taking one of the following corrective measures or taking some of them in combination.

- Change the orientation of the antenna of the television set or radio to find a position without reception difficulty.
- Separate the television set or radio from this product.
- Plug the power cord of this product into an outlet which is isolated from power circuits connected to the television set or radio.

About media











Please follow the local regulations to dispose of roll sheets or other media.





Safety Precautions











Symbols

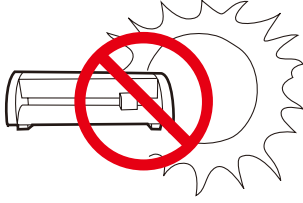



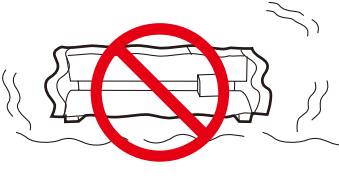

Symbols are used in this Operation Manual for safe operation and for prevention of damage to the machine. The indicated sign is different depending on the content of caution. Symbols and their meanings are given below. Please follow these instructions as you read this manual.

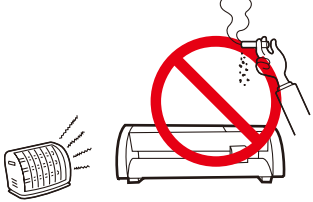
Examples of symbols

	Meaning
	Failure to observe the instructions given with this symbol can result in death or serious injuries to personnel. Be sure to read and observe the instructions for proper operation.
	Failure to observe the instructions given with this symbol can result in injuries to personnel or damage to property.
	This symbol indicates that the information is helpful in proper operation of the plotter.
	This symbol indicates that it is important to know of the information on proper operation of the plotter. Use this information for your operation.
	Indicates the reference page for related contents.
	The symbol "  " indicates that the instructions must be observed as strictly as the CAUTION instructions (including DANGER and WARNING instructions). A sign representing a precaution (the sign shown at left warns of hazardous voltage) is shown in the triangle.
	The symbol "  " indicates that the action shown is prohibited. A sign representing a prohibited action (the sign shown at left prohibits disassembly) is shown in or around the circle.
	The symbol "  " indicates that the action shown must be taken without fail or the instructions must be observed without fail. A sign representing a particular instruction (the sign shown at left instructs to unplug the cable from the wall outlet) is shown in the circle.

 WARNING	
Do not disassemble or remodel the plotter.	Handling of the power cable
 <ul style="list-style-type: none"> Never disassemble or remodel the plotter. Disassembly or remodeling can result in an electric shock or breakdown of the machine. Do not use the plotter in a damp place. 	 <ul style="list-style-type: none"> Use the supplied power cable. Take care not to damage, break or work upon the power cable. If a heavy material is placed on the power cable, or if it is heated or pulled, the power cable can break, thus resulting in fire or electric shocks.
Avoid locating the plotter in a damp environment.	
 <ul style="list-style-type: none"> Do not splash water onto the machine. Use in such an environment can give rise to fire, electric shocks or breakdown of the plotter. 	
In case abnormal event occurs.	
 <ul style="list-style-type: none"> Use of the plotter under an abnormal condition where the device produces smoke or strange smell can result in fire or electric shocks. If such an abnormality is found, be sure to turn off the power switch immediately and unplug the cable from the wall outlet. Check first that the plotter no longer produces smoke, and contact your distributor for repair. Never repair your plotter by yourself since it is very dangerous for you to do so. 	

 CAUTION		
A place exposed to direct sunlight	On an inclined surface	A place where temperature or humidity varies significantly
 	 	 <ul style="list-style-type: none"> Use the plotter under the following environmental conditions: Operating environment: 20 to 35° C 35 to 65% (Rh)
A place that vibrates	A place exposed to direct air flow from an air conditioner or the like.	Around a place where flame is used
 	 	 

 CAUTION	
<p>Be careful with the movable parts</p> <p> • Do not touch the rolling grit roller; otherwise, you may hurt your fingers or tear off your finger nails.</p>	<p>Sheets</p> <p> • Straighten the sheet of media, if significantly curled, before using it for printing. Heavily curled sheet affects the cutting (plotting) result.</p>
<p> • Keep your head and hands away from any moving parts during cutting (plotting) operation; otherwise, you may get your hair caught in the machine or get injuries.</p>	<p>Caution with cutters</p> <p> • Do not touch the cutter blade, which is very sharp.</p> <p>• Do not shake or swing the cutter holder; otherwise, the blade may come off.</p>
<p> • Wear proper clothes. (Do not wear loose-fit clothes or accessories). Bind a long hair.</p>	

Safety Labels

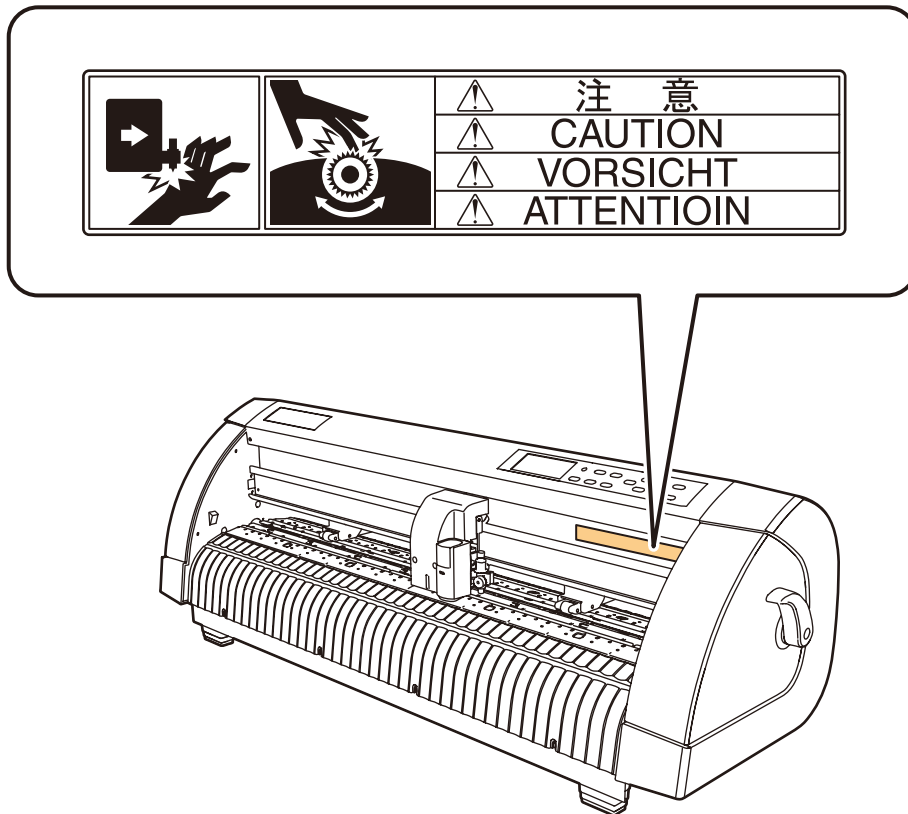

Checking the accessories

The articles illustrated below are supplied with your plotter as accessories. Check them for correct quantities and appearance. If you find any problem, please contact your distributor.

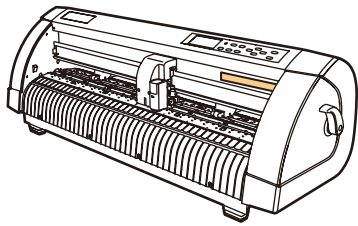

Main unit



Cutter blade
(for Vinyl)



Cutter holder
(Provided with blade)

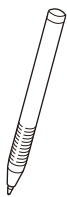

Ball-point pen
(Black, Marketed item)

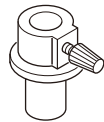

Ball-point pen adapter
(Mounted on the main
unit at the factory before
shipment)



Cap

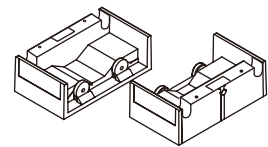

Roll-placing table

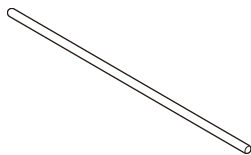

Sheet Support

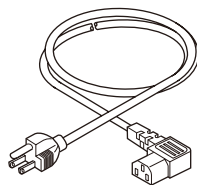

Power cable

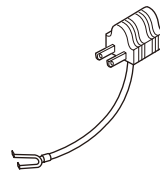

Grounded plug adapter
(This is not packaged
depend on the
destination)

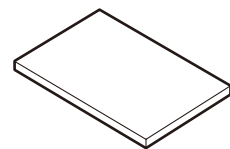

CD-ROM
(USB Driver)
(Plug-in software FineCut)

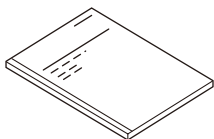

Quick Reference Guide

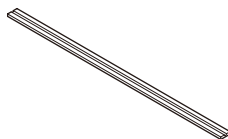

Pen Line

Configuration and function

The Front

Carriage

The carriage carries the pen and moves it up and down.

Operation panel

The plotter is operated and functions are set on the operation panel. (☞ P.10)

Power switch

The switch turn on/off the power. (☞ P.17, P.30)

Clamp lever

Pushing a lever down lowers a pinch roller and retain the sheet.

Platen

The sheet of media moves along the platen.

Grit roller

The grit rollers operate in combination with the pinch rollers to feed the sheet.

Pinch roller

The pinch rollers feed out the sheet while pressing it against the grit rollers.

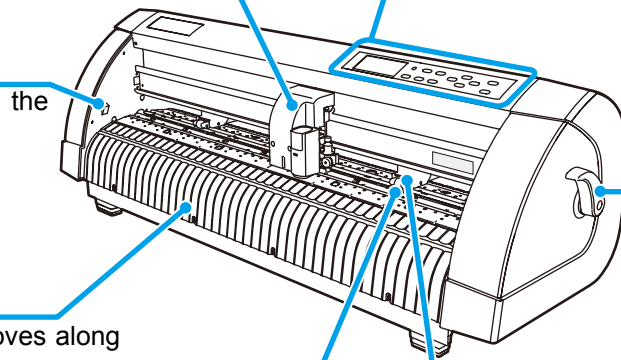

The Rear

Tray

Small tools, such as a retractable knife and other cutters, may be placed on the tray.

USB interface connector

The USB interface connector. Connected to the USB connector of the host computer through a USB interface cable. (☞ P.11)

Clamp pressure lever

This lever adjusts the force by which the clamp is held.

AC inlet

The power cable is connected to the AC inlet. (☞ P.11)

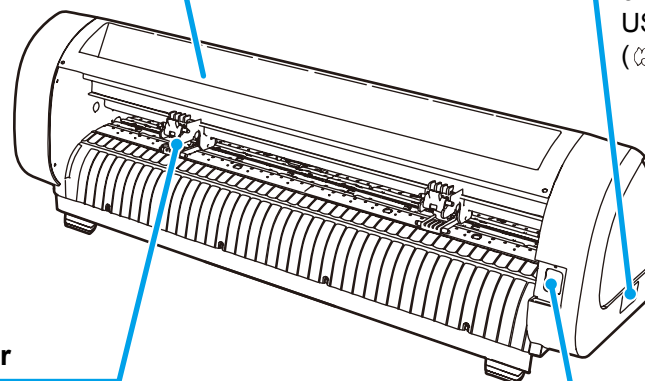

Operation Panel

Display panel

The display panel indicates tool conditions such as speed, pressure and offset, tool coordinates, functions and error messages.

SHEET SET key

Use this key for detection of the sheet or clearing of the detection result. (P.21)

POWER lamp

This lamp lights up when the power to the plotter is turned on.

FUNCTION key

Use this key to enter function setting mode.

JOG Key

Each of these arrow keys shifts the carriage or sheet in the direction of the arrow or changes settings. (P.10)

END key

This key cancels the last input value or returns the setting menu to the immediate higher level in the hierarchy. Use the key to detect only the sheet width.

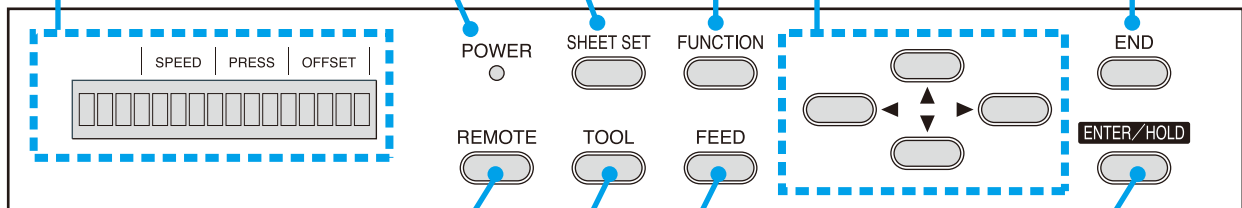

REMOTE key

This key switches the operation mode between REMOTE mode and LOCAL mode. If this key is pressed when the plotter is in operation, the plotter will come to a halt. Press the key again to restart the plotter,

TOOL key

Use this key to select a tool and establish tool conditions.

FEED key

Press this key to execute sheet feeding.

ENTER/HOLD key

This key registers the last input value as the setting value or returns the setting menu to the immediate lower level in the hierarchy. Use the key to correct the drifting of the sheet during cutting (plotting) operation.

Jog keys

The arrow keys are used as described in the table below.

	Before the detection of a sheet	After the detection of a sheet	When selecting a function	When selecting a setting value
	Detects the sheet width.	Shifts the carriage to the left.	—	—
	Detects the width and length of the sheet.	Shifts the carriage to the right.	—	—
	Detects the sheet width.	Move the sheet toward the rear of the plotter.	1Restores the previous function.	Selects the previous value.
	Detects the width and length of the sheet.	Move the sheet toward the front of the plotter.	Selects the next function.	Selects the next value.

In this manual, the sheets of media other than roll sheets are referred to as leaf sheets or cut sheets.

Connecting the cables

USB Cable Connection

When you want to connect the USB cable, you must observe the following notabilia.

Important!

- Do not plug in or unplug any cable during data transferring.
- Follow the instructions on the LCD if the wizard is displayed when connecting the USB cable.

Connecting USB driver

As for USB driver connection, refer to “USB Driver Installation Guide” in the supplied FineCut.

- (1) Set the CD supplied with FineCut into the disk drive.
- (2) Click [CD-ROM Contents] on the menu.
- (3) Open [usb11_installguid(en).pdf] for the plotter used in [Mimaki USB1.1 Driver] folder.

Connector ports

This plotter uses the USB connector for connection to the host computer.

Important!

- Connect or disconnect the connectors carefully. Applying undue force to a connector may damage the connector.

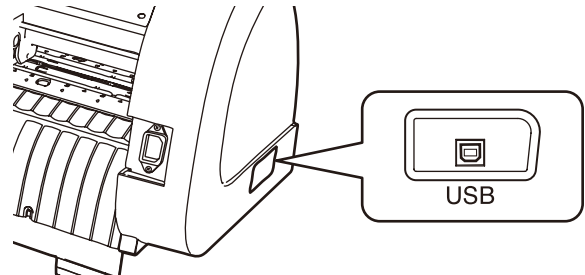

Connecting the power cable

After connecting the interface cable, you must connect the power cable. Connect the power cable with the plug outlet of the following power specifications.

- Voltage : AC100 - 240V \pm 10%
- Frequency : 50/60Hz
- Capacity : 145 VA or less

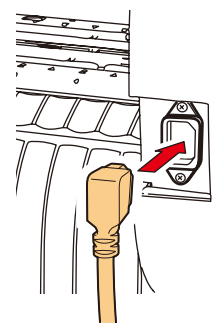

Be sure to connect the ground wire.

- Using without the ground wire causes the damage of this device and electric shock that may be very dangerous.

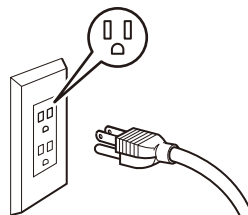

Regarding the use of two polar plug outlet, you must connect the auxiliary ground adapter to the plug of power cable.

- Earth the green wire (ground wire) of the ground adapter. If you cannot, consult with an electrician.

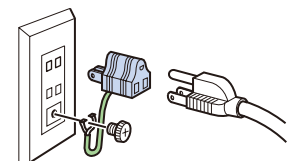

Operation flow

1

Installing a tool

See "Installing a tool" (👉 P.13)

2

Turning the power on

See "Turning the power on"
(👉 P.17)

3

Setting the tool conditions

See "Setting the tool conditions"
(👉 P.18)

4

Loading a sheet of media

See "Loading a sheet of media"
(👉 P.21)

5

Test cutting (plotting)

See "Test cutting (plotting)"
(👉 P.27)

6

Cutting (plotting)

See "Cutting (plotting)" (👉 P.28)

7

Turning the power off

See "Turning the power off"
(👉 P.30)

Installing a tool

For this device, you can use the following tools.

Cutter : Select this to cut the image printed on a sheet and to create the cut letters with the cutting sheet.

Pen (rollerball) : Select this to “trial-write” for confirming how to actually cut.

Pouncing Pin (option) : Select this to sketch the cutting line.

Using a cutter



- Don't touch the cutter blade with your fingers.
->Sharp cutter edge may cause to injure you.
- After setting the cutter, don't shake the tool.
->The cutter edge may pop out and may cause to injure you.

How to install a cutter blade

1 Take out the cutter holder.

2 Loosen the lock nut, and pull the adjusting knob out of the holder.

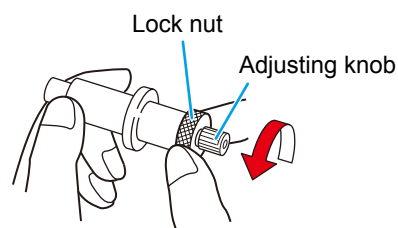

3 Insert the cutter blade into the adjusting knob using tweezers.

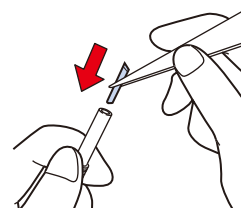

4 Tighten the lock nut.

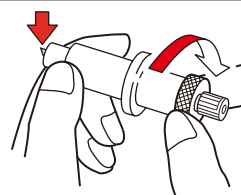

Adjusting the protrusion of the cutter blade

Adjust the cutter blade according to the types of the cutters and the sheet for use.

After adjusting the protrusion of the cutter blade, set the cutting conditions and conduct test cutting to check the cutting quality.

Important!

- Take care not to protrude the blade too much. If the cutter is used with its blade excessively protruded, the cutter can cut out the base paper, thus damaging the main unit.

1

Take off the cutter holder and loosen the Lock nut.

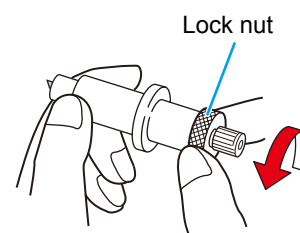

2

Turn the adjusting knob to adjust the protruding amount of the cutter blade.

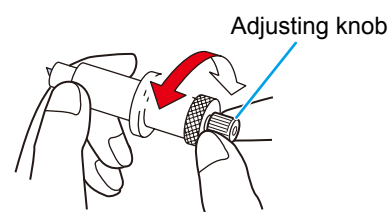

3

Tighten the lock nut so that the adjusting knob will not turn.



How to install the cutter

Important!

- Install the cutter to the tool holder of the carriage. Be sure to insert the cutter all the way in the tool holder.

1

Inset the cutter into the tool holder.

- Push the brim of the cutter against the holder.

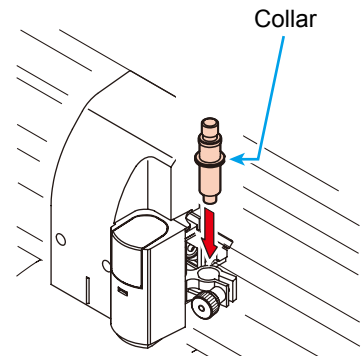

2

Fix the cutter holder.

- Turn the finger grip clockwise, and surely fix it.

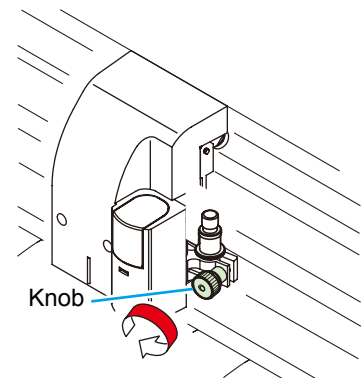

Important!

- Fix the cutter firmly. If not, accurate and high-quality cutting (plotting) will not be achieved.

How to Install a Ballpoint Pen

Important!

- When use a boll-point pen on the market, refer to the oeration manual and select a installable boll-point pen.

1

Put the cap on the pen adapter.

- Use the cap to adjust the pen height.

2

Insert the pen into the pen adapter.

- Insert the pen until the pen head reaches the cap.

3

Fix the pen tip.

- Tighten the fixing screw clockwise.
- Be careful not to over-tighten the fixing screw for the pen adapter. If tightened too much, the ball-point pen may crack.

4

Remove the cap.

5

Insert the pen adapter with the pen into the tool holder.

- Make sure that the collar of the pen adapter is rested on the holder.
- Set the adapter in such a way that the fixing screw will not obstruct operation.

6

Turn the knob of the tool holder clockwise to fix the tool.

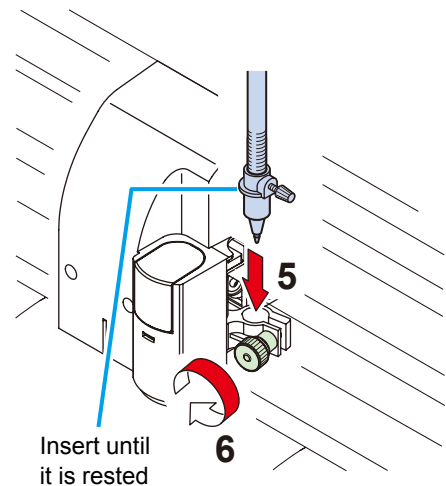
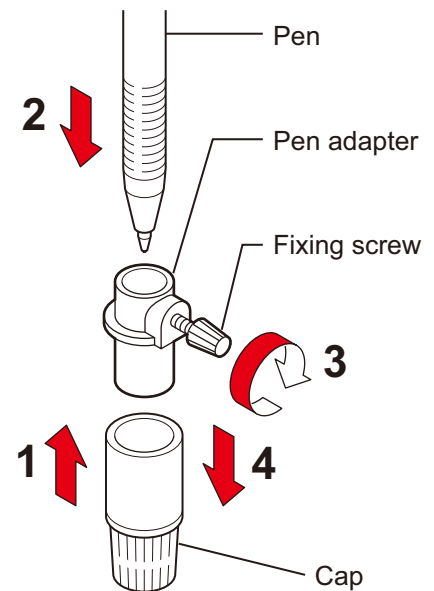

Insert until it is rested

Turning the power on

Important!

- Before turning the power on, check that the pinch rollers have been raised.
- Be sure to turn on the host computer before turning on the plotter. If this order is not correctly followed, the plotter can malfunction.
- Once the power is turned off, wait at least five seconds before turning the power on again.

1

Press the “ | ” side of the power switch.

- When the plotter is turned on, it will enter the first operation mode, which are followed by the subsequent modes. Refer to page 1-15 for the operation modes.

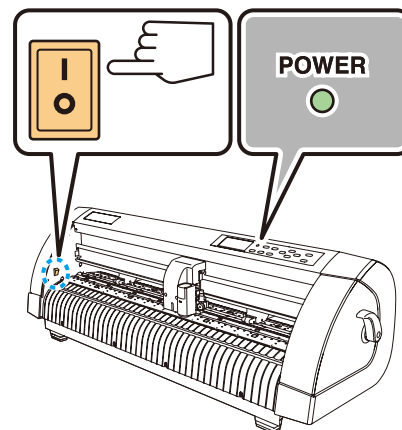

2

The POWER indicator lamp lights up green.

- The sheet suction fan rotates.

3

Check the receiving buffer.

- Then, the tool conditions for the currently selected tool appears on the LCD.

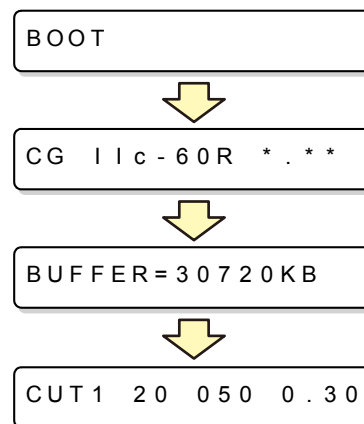

Setting the tool conditions

You must set the tool conditions adjusting to your use.

Kinds of the Tool Conditions

The kinds of the tool conditions include cutting and plotting conditions.
See P.18 for the way of setting tool conditions.

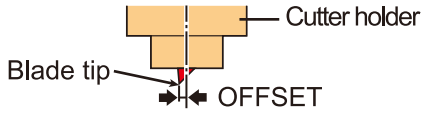
Kinds	Description
<p>Cutting Condition (CUT1 ~ CUT5)</p> <div style="border: 1px solid black; padding: 2px; margin-bottom: 5px;">CUT1 20 050 0.30</div> <div style="border: 1px solid black; padding: 2px; margin-bottom: 5px;">CUT2 20 080 0.30</div> <div style="border: 1px solid black; padding: 2px; margin-bottom: 5px;">CUT3 05 150 0.30</div> <div style="border: 1px solid black; padding: 2px; margin-bottom: 5px;">CUT4 20 060 0.30</div> <div style="border: 1px solid black; padding: 2px;">CUT5 20 070 0.30</div>	<p>This is the tool conditions for using the cutter.</p> <div style="border: 1px solid black; padding: 5px; margin-bottom: 10px;">CUT1 20 050 0.30</div> <p>OFFSET The distance from the center of the cutter holder to the cutter blade</p> <p>PRESSURE The pressure required for cutting</p> <p>SPEED The speed of cutting</p> 
<p>Plotting Condition (PEN)</p> <div style="border: 1px solid black; padding: 2px;">PEN 40 080</div>	<p>This is the tool conditions for using a pen.</p> <div style="border: 1px solid black; padding: 5px; margin-bottom: 10px;">PEN 40 080</div> <p>You need not to set OFFSET.</p>



- Besides the above list, able to set the cutting condition for "POUNCHING" and "HALF CUT". Refer to the operation manual for more detail.

Set the Tool Conditions.

1

Press the **TOOL** key several times to select a tool condition for setting.

TOOL

CUT2 20 080 0.30

- Refer to P.18 for selectable tool conditions
- Select [CUT2] here.

2

Press the jog key  or  to change the SPEED value.



CUT2 50 080 0.30

- The setting values : 1 to 10cm/s (settable by 1cm/s step)
15 to 50cm/s (settable by 5cm/s step)
- Increase the value, and you get the higher speed. Decrease the value, and you get the lower speed. (Set 20 to 30cm/s regularly).

3

Press the **ENTER/HOLD** key or jog key  to move the cursor to PRESSURE.

ENTER/HOLD

 or

CUT2 50 080 0.30

- When you want to return to the previous setting item, press the jog key .

4

Change the value of PRESSURE using the jog key  or .





CUT2 50 100 0.30

- The setting values : 10 to 20g (settable by 2g step)
20 to 100g (settable by 5g step)
100 to 400g (settable by 10g step)

5

Press the **ENTER/HOLD** key or jog key  to move the cursor to OFFSET.

ENTER/HOLD

 or

CUT2 50 100 0.30

- When you want to return to the previous setting item, you must press the jog key .

6

Press the jog key  or  to change the value of OFFSET.



CUT2 50 100 0.35

- The setting values : 0.0 to 2.5mm (settable by 0.05mm step)
- If you have selected the POUNCING condition (PIN) in the Step 1, you must set the pounce interval here. (The setting value: 1 to 100mm (1mm step))

7

Press the **ENTER/HOLD** key or jog key  to secure the setting value.

ENTER/HOLD



or



CUT 2 50 100 0.35

Important!

- When you set PRESSURE to lower than 20g in the Step 4, you must set the setting of SPEED to lower than 10cm/s in the Step 2. Otherwise, the setting may cause the tool to be lifted, and blurred plotting as well as undone cutting.
- Don't perform cutting adjustment only with the protruding amount of the cutter edge while PRESSURE (cutting pressure) remains to be set hard. If cutting is made with the less protruding amount of the cutter edge but with stronger PRESSURE, strange sound may come out during cutting. In addition, the bottom of the cutter and the sheet scrape each other, which may cause the sheet surface to have scratches and which may lower the cutting quality.

Loading a sheet of media

Either a leaf sheet (cut sheet) or a roll sheet can be loaded on the plotter. The pinch rollers and grit rollers hold the sheet in position. Locate the pinch rollers so that they match the sheet to be used.

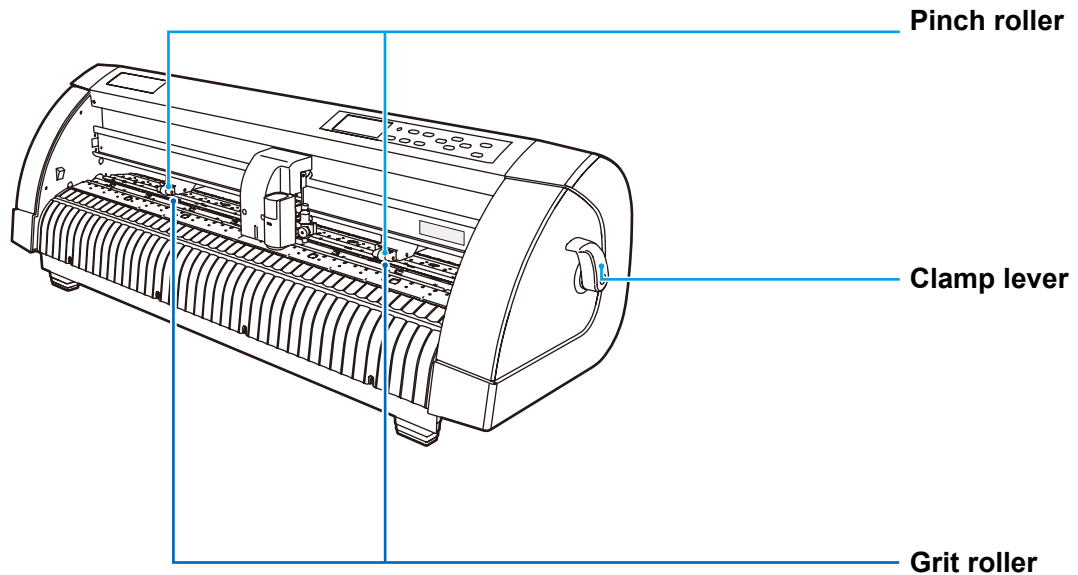

Sheet width available

	mm	inch
Sheet width available	90~740	24

Sheet detection



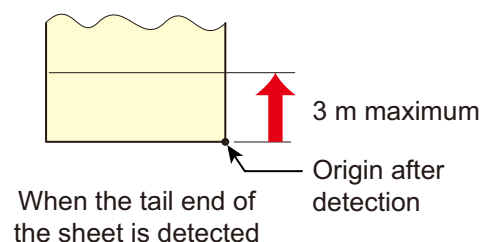

The width and length of the sheet are detected by pressing or key depending on the sheet loaded. (P.22)

Important!

- Once the sheet length has been detected, if the received data is larger than the sheet, the portion of data that exceeds the sheet cannot be used for cutting. If the sheet length is not detected, the plotter will terminate cutting operation when data goes beyond the sheet.
- If the sheet sensor function is set to [OFF], a press of a jog key will make the plotter perform the same sheet detection as the case key is pressed. (Only the sheet width is detected.)
- The maximum length that can be detected at the front and rear ends of the sheet of media is 3 m.



Method of detecting a sheet

When a sheet of media is set, the following two displays will appear alternately on the LCD panel. Align to the direction of the set sheet, and press the jog keys  ,  ,  or  .

ROLL < R > LEAF

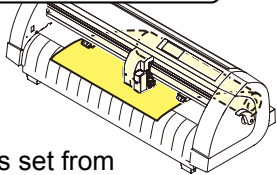



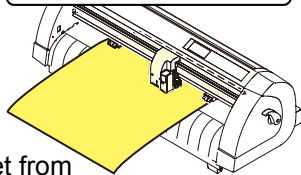

R set
A sheet is set from the rear side.

ROLL ^ F v LEAF

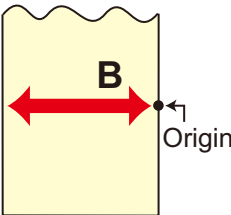
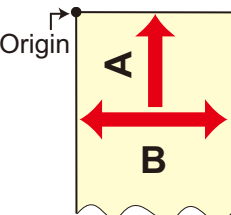
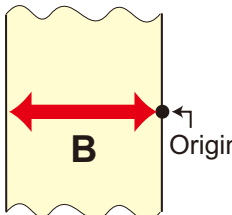

F set
A sheet is set from the front side.

The plotter uses the five different methods to detect a sheet of media as shown below.

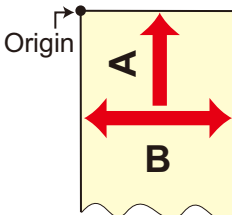
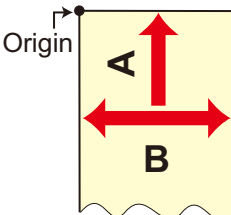
Key	 This key sets the roll sheet in the back side.	 This key sets the discard in the back side.	 This key detects only the sheet width.
Detecting method	The sheet width is detected  Front side of the plotter	After the sheet width is detected, The back end of the sheet is detected.  Front side of the plotter	The sheet width is detected  Front side of the plotter
Example of display after the sheet detection	A=**** B=123	A=567 B=123	A=**** B=123
Key	 This key sets the roll sheet in the front side.	 This key sets the discard in the front side.	
Detecting method	After the sheet width is detected, The back end of the sheet is detected.  Front side of the plotter	After the sheet width is detected, The back end of the sheet is detected.  Front side of the plotter	
Example of display after the sheet detection	A=**** B=123	A=567 B=123	

Important! • When the detected length is 3 m or more, the display “ **** ” will appear on the LCD.



• When a long sheet of media is used or a sheet which has already been drawn out is used from its middle area, the sheet detection will require an extended period of time. In such a case, the detection time can be reduced by detecting only the sheet width.

Loading a leaf sheet (cut sheet)

1

Press the **SHEET SET** key to switch to **NOT READY** mode.

ROLL < R > LEAF

- You need not to do so if it's already in the NOT READY mode.
Start operation from the Step 2.

2

Load the leaf sheet on the platen.

- (1) Push a clamp lever up to raise a pinch roller.
- (2) Set the right end of the sheet considering the platen vertical rib as the measure.
Or, align the near end of the sheet in parallel with the platen.

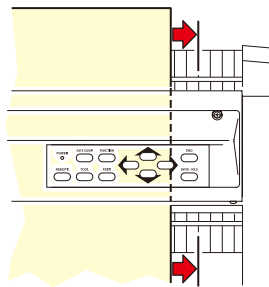
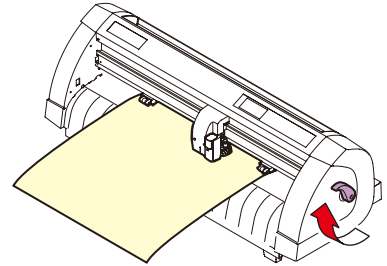

3

Move the pinch rollers so that they suit the sheet width.

- Locate each of the pinch rollers 5 mm or more inside the sheet edge; otherwise, the sheet can slip off the pinch rollers while it is being fed.

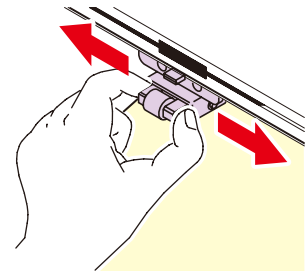

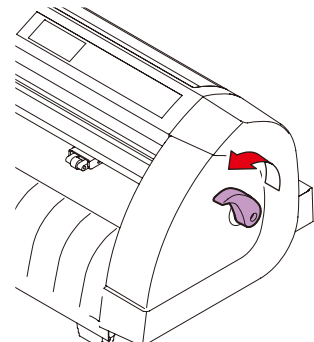

4

Push a clamp lever down to lower the pinch roller.



5

Press the jog key  or  to select "LEAF" .

- "Sheet detection" ( P.21)
- : In the case the sheet is loaded from the rear
- : In the case the sheet is loaded from the front

6

Start detecting the sheet.

- This plotter cannot detect the discard sheet of longer than 3m.

Displays the detected size of the leaf sheet.

A = 6 5 4 B = 4 5 9



Unit : mm

CUT1 20 050 0.30

Displays the current settings of tool conditions.

How to Place the Roll Sheet

If you want to use the roll sheet, you must mount the roll-placing table.

1 Raise the clamp lever.

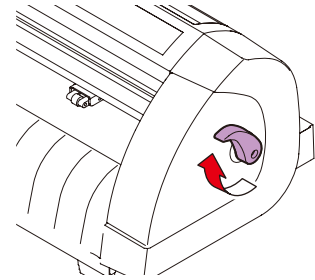

2 Lay down the roll-placing table, fitting to the width of the roll sheet.

- As the roll-placing table has a magnet, just attach it to the device and it is fixed.
- Fix the roll-placing table 2 to 3mm away from the sheet width. Pressing the both ends hard may cause the roll not to be rotated, resulting in no sheet feeding.

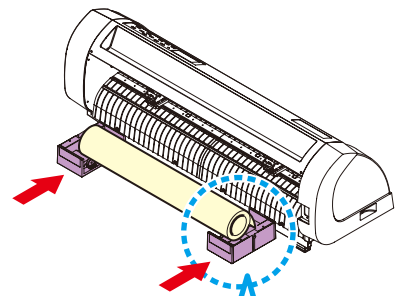

3 Lay up the roll sheet on the roll-placing table.

- Be careful about the sheet direction.

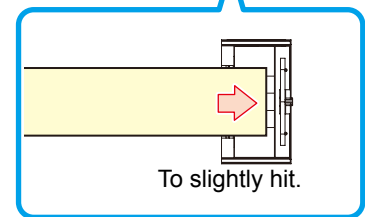
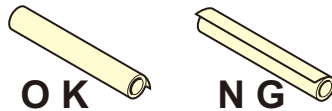

4 Pull out the sheet for maintaining.

- (1) Pull the sheet tightly and take up the slack.
- (2) Make sure that the sheet is loaded without slack, then raise the clamp lever.

- When the power is on, the absorbing fan is turned on to absorb the roll sheet.
- If the power is not on, the absorbing fan is not turned on. Therefore, pressing the sheet with your left hand so as not to be deformed, raise the clamp lever.

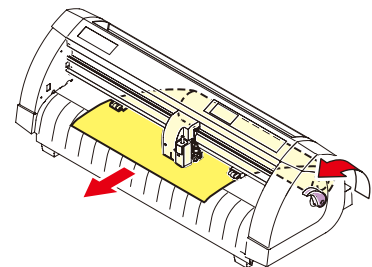

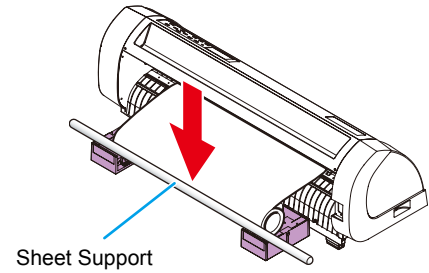

5

Install the sheet support to the roll table as shown in illustration.

**6**

Press the jog key  or  to select [ROLL].

- "Sheet detection" ( P.21)
-  : In the case the sheet is loaded from the rear
-  : In the case the sheet is loaded from the front

7

Start detecting the sheet.

Displays the detected size of the leaf sheet.

A = 6 5 4 B = 4 5 9

 Unit : mm

CUT 1 20 050 0.30

Displays the current settings of tool conditions.

8

Press the  key to pull out the sheet of the length you want to use.

Important!

- Before you use the roll sheet, previously pull out the sheet of the length you use to make enough room. By feeding out the sheet, you can verify if there is any sheet misalignment or not.

Test cutting (plotting)

Execute test cutting (plotting) to confirm the tool conditions.
In the test cutting, the plotter cuts two squares.

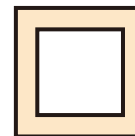

Important!

- When the cutter blade is worn and dull, you can use it temporarily by enhancing the value of PRESSURE. However, you are recommended to replace the worn cutter blade with a new one to ensure a satisfactory cutting quality.



- When the tool conditions are proper, the results of test cutting (plotting) are as follows:
The two squares are cut perfectly.
The base sheet remains uncut.
No corner of the squares is round.
No corner of the squares is curled-up.

1

Confirm that the plotter is in the local mode.

CUT1 20 050 0.30

2

Press the **FUNCTION key a few times to select [SQUARE CUT].**



SQUARE CUT <ENT>

3

Press the **ENTER/HOLD key .**

- The plotter will execute test cutting (plotting) and then return to the local mode display.

Change the settings of the cut conditions according to the test cutting (plotting) results.

Cut Condition	Cause	Remedy
Some parts uncut.	The blade floats above the sheet because of a too high cutting speed.	Lower the speed.
		Tighten up the thumbscrew for the tool holder.
The base sheet has been cut.	Too high pressure.	Lower the pressure.
	Too large protrusion of the cutter blade.	Adjust the protrusion of the cutter blade.
Any of the square corners rounded.	Improper OFFSET value.	Adjust the OFFSET value so that it suits the cutter blade in use.
Any of the square corners curled-up.	The protruding amount of the cutter edge is too much. The cutting pressure is higher. The [COMPENSATION PRESSURE OFFSET value] is greater. More than two out of the above fall under this category.	Adjust the protrusion of the cutter blade.
		Adjust the cut pressure
		Adjust the ADJ-PRS OFS value

Cutting (plotting)

You can start cutting (plotting) after completion of setting up a tool, loading a sheet and setting the tool conditions.

Setting the origin

The origin is a reference point for the cutting (plotting) data.





When the origin is to be changed, set the new origin before starting cutting (plotting).

Important!

- Change the origin before you make the plotter start cutting for the next data; otherwise, cutting will be performed over the previous data.

1

Move the head to a point at which the new origin is to be set.

- : Moves the head to the right.
- : Moves the head to the left.
- : Feeds the sheet toward the rear of the plotter.
- : Feeds the sheet toward the front of the plotter.
- Every time you press the  key, the tool will move up and down alternately. This helps you to set the origin at a correct position.

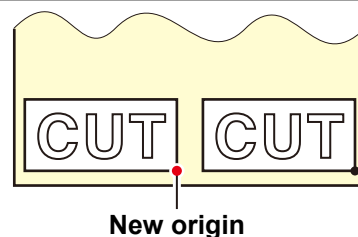

2

Press the  key to register the origin.

- The display panel will show the effective cutting area first and then the tool conditions.



** ORIGIN **



A = * * * * B = * * * *



CUT 1 20 050 0.30

Start cutting (plotting)

1

After completion of setting the origin, press the **REMOTE** key.



CUT 1 * REMOTE *

- The display changes to REMOTE.

2

Send the data to the plotter.

- On receiving the data, the plotter performs cutting (plotting) while displaying the remaining amount of the data.
- Upon completion of cutting (plotting), the display changes as shown at right.

CUT 1 * 1356KB *



When the cutter is selected

CUT 1 * REMOTE *

When the pen is selected

PEN * REMOTE *

Bringing the cutting (plotting) to a halt

To temporarily stop the plotter during cutting (plotting), press the **REMOTE** key once. Another press of the key will make the plotter resume cutting (plotting).

Important!

- In case the sheet has slipped off the plotter during cutting operation, turn off the power immediately; otherwise, the main unit may be damaged.



- The LCD will show the following error message if you try to execute any function that can initiate some action during temporary suspension or any operation that can affect the command coordinate system.

ERR34 DAT REMAIN

- If the error message appears, let the plotter complete the cutting for the remaining portion of the data or discontinue the cutting by executing data clearing (OPERATION MANUAL).

Turning the power off

When plotting is completed, press the “ O ” side of the power switch to turn the power off.

Important!

- Once the power is turned off, wait at least five seconds before turning the power on again.

1

Confirm that the plotter is not receiving any data.

- Make sure that the display is indicating REMOTE or LOCAL.

CUT1 * REMOTE *

CUT1 20 050 0.30

2

Press the “ O ” side of the power switch.

- The POWER lamp on the operation panel turns off.

