

Inkjet printer JV150-130/160

Requests for Care and Maintenance

This machine is a precision machine equipped with extremely fine mechanisms. Especially, the nozzle surface of the heads from which the ink is discharged is affected even by a slightest attachment of dust or paper powder and the proper printing results could not be obtained. With a view to using this machine in a better condition, we would like to recommend performing the following care and maintenance on daily basis.

1. When to care

When to care	What to care	Reference Page
When the Machine Is Not Used for a Long Time	Perform "Storage Wash"	P.3
Once a day (at the end of the daily work)	Surroundings of the heads	P.4
	Capping station	P.5
	Wiper	P.6
	Media press	P.7
	Media sensor	P.7
Once a week (at the end of the work on weekend)	Jam sensor	P.7
	Cleaning the Platen	P.8
	Exterior	P.8
Depends on the type and color of the ink	Waste ink tank	P.8
	Ink Discharge Passage	P.9
Replace or clean when it is dirty	Ink Maintenance	P.10
	Replacing the exhaust BOX filter or exhaust BOX.	P.10
	Replace the CP pad set.	P.11
	Cleaning or replace the pinch roller.	P.12



- Tools required for maintenance
 - Cleaning stick (SPC-0527)
 - Cleaning solution MS2/ES3/HS kit 200 (SPC-0369) / Cleaning-Solution Bottle kit A29 (SPC-0137)
 - Cotton swab
 - Safety glasses
 - Gloves
 - Soft fabric

2. Safety Precautions

⚠ CAUTION



- Pay close attention to ventilation and be sure to wear the included safety glasses and gloves provided, and the filtering face mask, when handling ink, maintenance cleaning solution, waste ink, or other solutions used in this machine. Failure to do so may result in ink or other liquids splashing and coming into contact with the skin, eyes, or mouth.

- Before cleaning, turn off the power switch and disconnect the power cable. It may cause an unexpected accident.
- There are precautionary notes on ink on the ink cartridge. Read it carefully and fully understand it before using it.
- Before using ink and cleaning solution, be sure to read the Safety Data Sheet (SDS).
- Keep ink away from fire. Also, be sure that the room is well ventilated when using or handling ink.
- Immediately wipe off any ink, maintenance washing liquid, waste ink, or other liquid used with the product that contacts your skin. Wash using soap and rinse with plenty of water. Failure to wash off liquid may result in skin inflammation. If your skin becomes irritated or painful, seek medical attention immediately.
- If ink, maintenance washing liquid, waste ink, or any other liquid used in the product comes into contact with your eyes, rinse immediately with plenty of clean water. Rinse for at least 15 minutes. If you wear contact lenses and they can be easily removed, remove after rinsing for at least 15 minutes with clean water. Be sure to rinse the undersides of your eyelids. Failure to rinse off liquid may result in blindness or impaired vision. If your eyes become irritated or painful, seek medical attention immediately.
- If ink, maintenance washing liquid, waste ink, or any other liquid used in the product enters your mouth or is swallowed, gargle with water immediately. Do not induce vomiting. Seek medical attention promptly. Inducing vomiting may cause liquid to enter the airway.
- If a large amount of vapor is inhaled, move to a well-ventilated area, keep warm, and rest in a posture that allows easy breathing. If the condition does not improve, seek medical attention promptly.
- To ensure ink ejection stability, this machine must periodically eject (flush) a small amount of ink depending on the ink type when it is not used (output) for a long time. When not using this machine for an extended period of time, execute the [CUSTODY WASH] function, ("When the Machine Is Not Used for a Long Time (CUSTODY WASH)" Chapter 4 of Operation Manual) and turn off only the power button on the front panel. The main power switch on the right side should be on (in the state of I) and the outlet should be inserted.



- When ink is mixed with water or alcohol, aggregates are generated. Do not allow water or alcohol to deposit to the nozzle surface, around the head, cap, and wiper.



- Do not use chemicals containing benzene, thinner or abrasives. The cover surface may be altered or deformed.



- Do not lubricate the machine with lubricating oil. There is a risk of failure.
- Never disassemble the machine. Failure to do so may cause electric shock, fire or damage.



- Keep children away from this machine.

- Make sure that no moisture enters the machine. If the inside gets wet, it may cause electric shock, fire and damage.

3. Installation environment

- Use this printer as much as possible in a dust-free environment. Fans and air-blowers could cause the dust scattering.
- The using environment of this printer is from 20 to 30°C (68°F to 86°F) in temperature and from 35 to 65 % in relative humidity. Avoid the use of this printer at a temperature and humidity higher or lower than the indicated ranges.

4. When the printer is not used for a long period

When the printer is not to be used for a period of one week or above, perform the cleaning of the heads and nozzles and the ink discharging channel before storing this printer.

5. Storage of ink cartridge

Be careful of the followings to store.

- Store the ink cartridge in no direct sunlight, and no high humidity.
- As it's a delicate product, do not drop it.
- Inc IC chip should not be contaminated and discharged static electricity.
- Be sure to store the ink cartridge and the ink IC chip together.

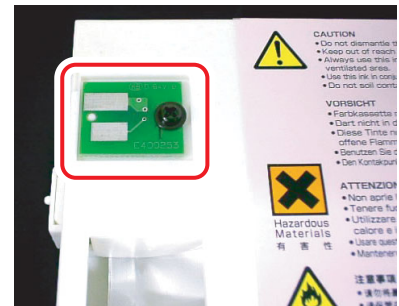

The ink IC chip mounted on the ink cartridge

6. Storage of media

Media should be stored in the little dust area, and not in direct sunlight. Avoid storing the media in the area with high temperature and high humidity.

7. Daily care



- When possible, use the cleaning stick (SPC-0527) for cleaning around the head/ capping station/ wiper. Using the other cotton bud may attach lint, then it may damage the machine.
- Be sure to perform maintenance for the ink cap and the wiper of capping station every day. If you leave it dirty, dirt may adhere to the nozzle surface, or, dust and dry ink may be rubbed against the nozzle. It may cause discharge defect.
- Clean the bottom of carriage every day so that it will not get dirt from inks or dusts. If you leave it dirty, dust and dry ink may be rubbed against the nozzle at wiping operation when performing head cleaning.
- When you clean the carriage bottom surface, fully be careful not to rub the nozzle surface.

(1) Surroundings of the heads ("Cleaning the Head and the Area around It" Chapter 4 of the Operation Manual)

- Cleaning solution MS2/ES3/HS kit 200 (SPC-0369) / Cleaning-Solution Bottle kit A29 (SPC-0137)



- The heads and their surroundings are the parts most liable to be tainted in this machine and if tainted, it could cause adverse effects to the functions of the machine and the results of the printings. Moreover, as the head itself uses very fine mechanisms, sufficient precautions are required for the care and maintenances.

1 Move the carriage to the left and open the maintenance cover.

- Refer to the Step 1 to 4 of Chapter 4 "Cleaning the Head and the Area around It" of the user's manual to perform the operation.

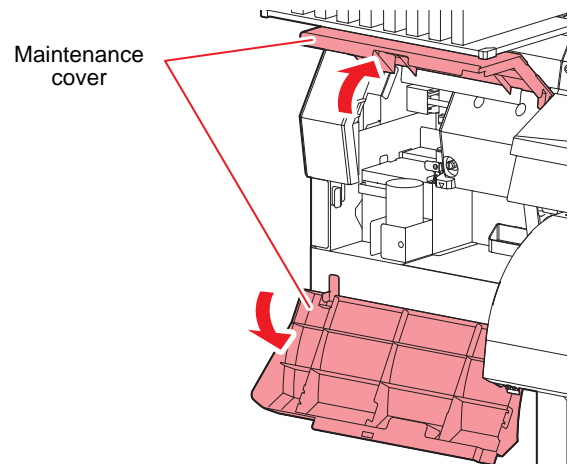

2 Soak the clean stick or the waste cloth in the maintenance cleaning liquid and wipe off an accumulated ink on the side of the head and on the bottom surface of the slider.

- Never rub the nozzles.

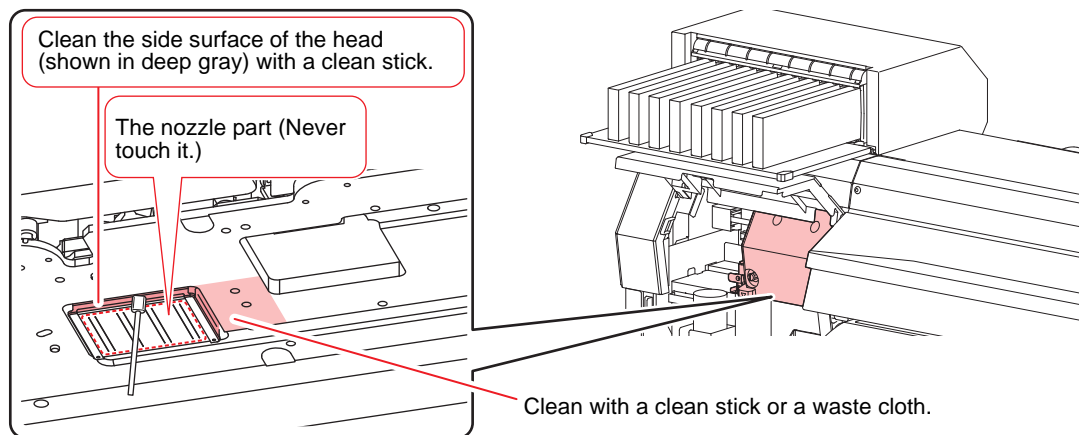

(2) Capping Station ("Cleaning around the wiper" Chapter 4 of the Operation Manual)

The surrounding area of the cap is also liable to be stained by the dust and ink. It is recommended to clean the head frequently using the cleaning liquid for maintenance suitable for the ink used to avoid the stains on the head.

- Cleaning solution MS2/ES3/HS kit 200 (SPC-0369) / Cleaning-Solution Bottle kit A29 (SPC-0137)

1 Move the carriage and open the maintenance cover.

- Refer to the Step 1 to 3 of Chapter 4 "Cleaning around the wiper" of the user's manual to perform the operation.

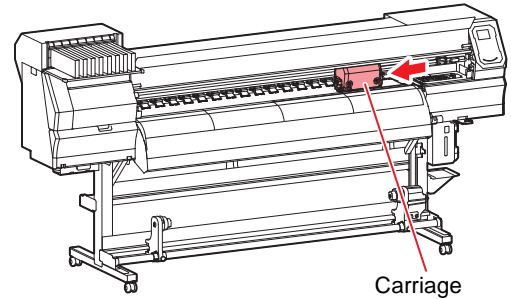

2 Clean the cap.

- Dip the clean stick into the cleaning liquid for maintenance and wipe off the cap. Wipe off so that cleaning solution for maintenance will not remain.

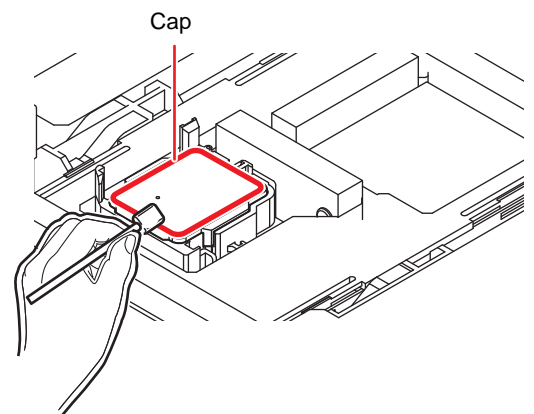

(3) Wiper ("Cleaning around the wiper" Chapter 4 of the Operation Manual)

On the wiper, the ink, dust and paper powder are liable to accumulate. Check the state of the wiper and if it is stained, clean it.

- Cleaning solution MS2/ES3/HS kit 200 (SPC-0369) / Cleaning-Solution Bottle kit A29 (SPC-0137)

1 Move the carriage and open the right maintenance cover.

- Refer to the Step 1 to 3 of Chapter 4 "Cleaning the Wiper and Cap" of the user's manual to perform the operation.

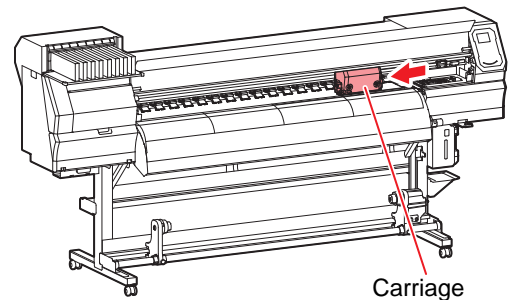

2 Clean the wiper.

- Remove the wiper by holding the projections at its both ends.
- Wipe off the ink sticking to the wiper and bracket with a clean stick dipped in cleaning solution for maintenance. Wipe off so that cleaning solution for maintenance will not remain.

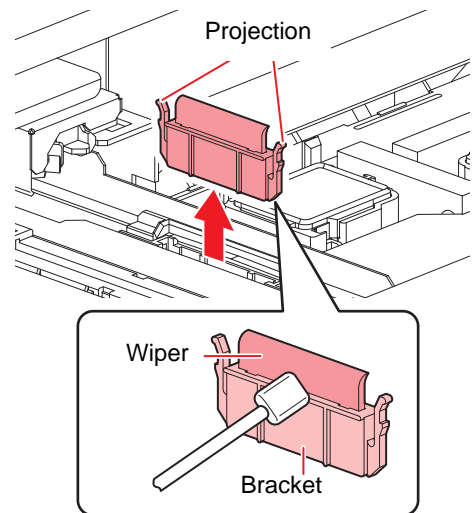

Further, in the cases as explained below, replace the wiper with the new one (SPA-0134) in accordance with "Replacing the wiper" on Chapter 4 of the Operation Manual.

- When the wiper is deformed
- When the stuck ink can not be wiped off
- When the warning for wiper replacement is indicated

(4) Media press (“Cleaning the Media Press” Chapter 4 of the Operation Manual)

When the cut dust of the media and other dusts accumulate between the media holder and the platen, it could cause the risks that the transfer of the media could not be performed properly or such dusts stick to the nozzles and this could interfere the proper printings. You are recommended to clean it frequently.

(5) Media sensor (“Cleaning the Media Sensor” Chapter 4 of the Operation Manual)

The media sensors are located on the platen in the backside and the bottom surface of the head.

If the dusts and ink accumulate on the sensor, it could cause false detection of the media or the register mark. Wipe off the sensors with soft cloth or clean sticks.



- For the cleaning of the media sensors, never use the solvent.
- When the sensor is heavily stained, use a soft cloth soaked in a neutral detergent diluted with water, wrung out, and then wiped off.

The backside of the machine

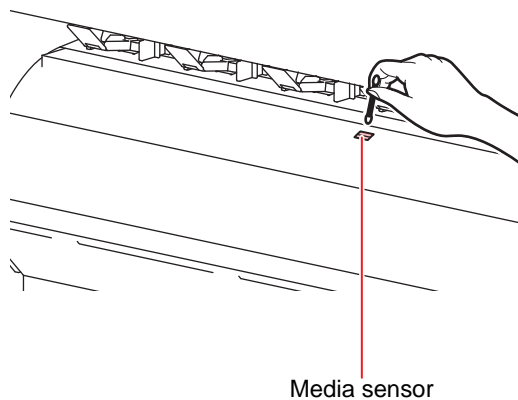

The lower surface of the head

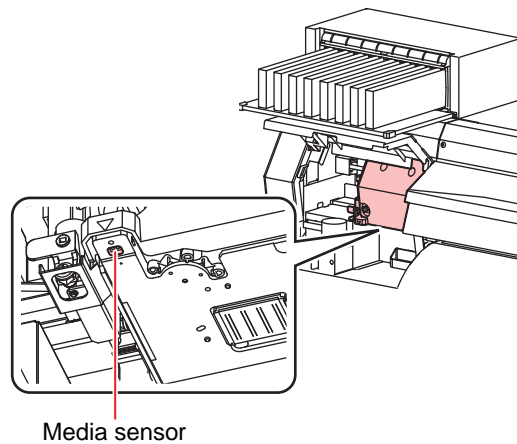

(6) Jam sensor (“Cleaning the Jam Sensor” Chapter 4 of the Operation Manual)

The jam sensor unit is attached to the right side of the carriage. If ink stains or dust accumulate on the sensor unit, it may cause a media jam. Clean the jam sensor periodically.

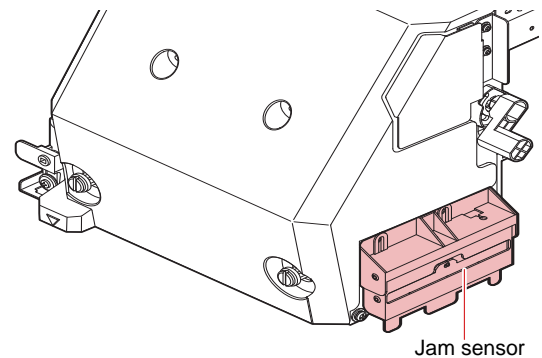

8. Periodically care (Once a week)

Users are advised to perform the maintenance works described below once a week so that the printer will keep its high performance and accuracy over an extended period of its life.

(1) Platen (“Cleaning the Platen” Chapter 4 of the Operation Manual)



- Turn off the main power and unplug the power cable before maintenance.

Continuing to use the media while it is dirty may cause media to be fed incorrectly, or rubbing dirt or solid ink onto the head nozzle surface, resulting in discharge failure (nozzle clogging, deflection, etc.).



- Do not allow liquids to enter the machine. There is a risk of equipment failure, electric shock, or fire.



- If the dirt is noticeable, use a soft cloth soaked in a neutral detergent diluted with water, wrung out, and then wiped off.
- Before cleaning the platen, make sure that the platen has cooled adequately.



- The groove that slides the media press and the groove that cuts the media are particularly easy to collect dust. Please carefully remove the dust.

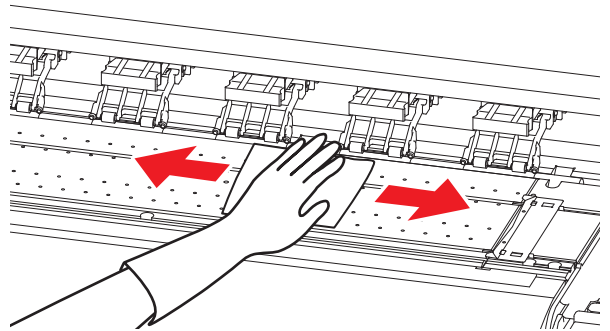

(2) Exterior (“Cleaning the Exterior Surfaces” Chapter 4, Operation Manual)

When the exterior surfaces of the machine are stained, dampen a soft cloth with water or a neutral detergent diluted with water, squeeze it, and wipe the surfaces with the cloth.

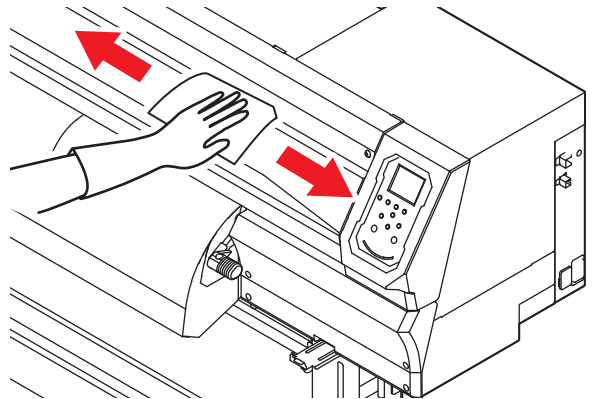

(3) Waste ink tank (“If a Waste Ink Tank Confirmation Message Appears” Chapter 4 of the Operation Manual)

Check whether the waste ink tank is full or not. Take care so that the waste ink never overflows the tank.



- Check the waste ink level in the waste ink tank frequently. Continuing to use the product without disposing of the waste ink may result in waste ink overflowing from the waste ink tank.

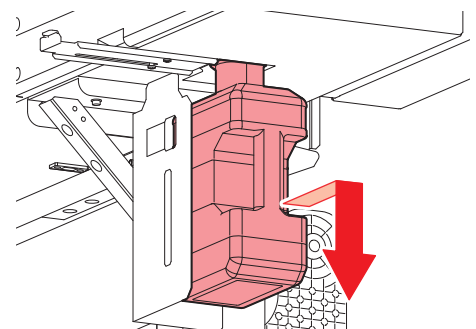

(4) Ink Discharge Passage (“Washing the Ink Discharge Passage” Chapter 4 of the Operation Manual)

Wash the ink discharge passage (DISWAY WASH) regularly (about once a week) to prevent the head nozzles from clogging due to ink coagulation inside the passage.



- Before washing the ink discharge passage, make sure that the maintenance washing liquid is set. If the maintenance washing liquid is not set, washing operation will not be conducted and the passage could be clogged.

1 Select “MAINTENANCE” menu → “STATION” → “DISWAY WASH”.

- Refer to the Step 1 to 3 of Chapter 4 “Washing the Ink Discharge Passage” of the user’s manual to perform the operation.
- The carriage will move onto the platen.

2 Open the front cover.

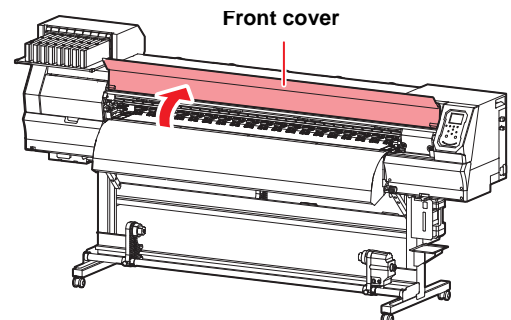

3 Press [ENTER] key.

- Dry suction operation is performed repeatedly until the washing work is completed.

4 Fill up the cap with cleaning solution for maintenance.

- If the cleaning solution cartridge is usable, maintenance solution is automatically filled. If there is not enough maintenance solution, press the [FUNC2] key to add maintenance solution.

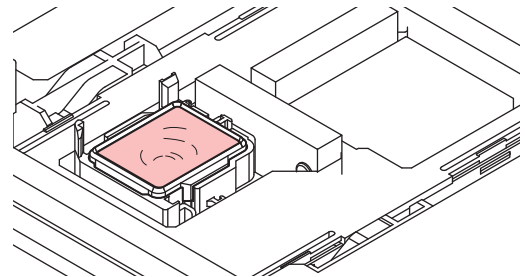

- If the cleaning solution cartridge is not usable, suck maintenance solution into a dropper and fill up the cap with it. Fill up the cap with maintenance solution on the verge of overflow from the cap.

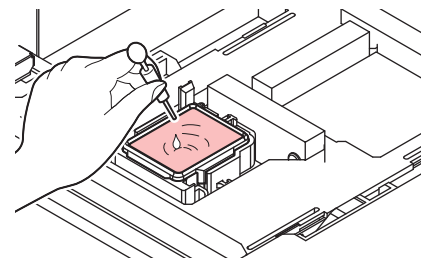

5 Close the front cover and press the [ENTER] key.

9. Ink Maintenance ("Ink Maintenance" Chapter 5 of the Operation Manual)

Shake the ink periodically. If you do not shake the ink periodically, the print quality may deteriorate rapidly. The frequency of shaking depends on the type and color of the ink.

Please use our recommended ink cartridge.

The frequency of shaking (recommended) is as follows. Refer to Chapter 1 "Inserting Ink cartridges" in the operation manual for how to shake. Shake the 2L ink pack in the same way. However, the MBIS (optional) must be attached and removed no more than 10 times in total.

- Solvent ink: Once a month
- Sublimation dye ink: Once a week
- Orange ink: Around once a week.
24 hours after the last printing.

If the printer is not used for over a week, please remove the orange cartridge and shake gently and operate [INK FILLING (Hard cleaning)]. (Refer to operation manual)

10. Replace or clean when it is dirty

(1) Replacing the exhaust BOX filter or exhaust BOX.

Replace the exhaust BOX filter (product number: SPA - 0249) or the exhaust BOX (product number: SPA - 0248) when it is dirty with ink.

1 Remove the tabs (2 locations) on the exhaust BOX.

- There are tabs engaged at the rear of the exhaust box also.

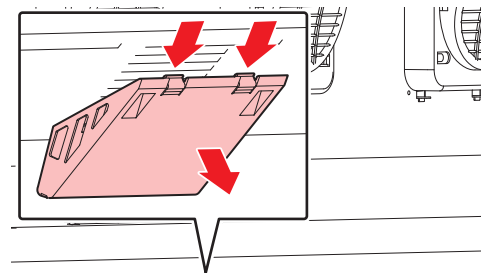

2 Remove the exhaust BOX and exhaust BOX filter.

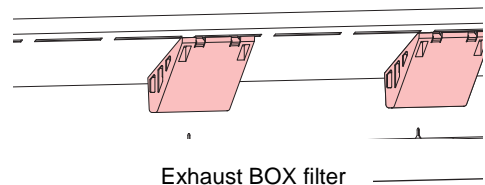

3 Replace the exhaust BOX filter or the exhaust BOX with a new one.

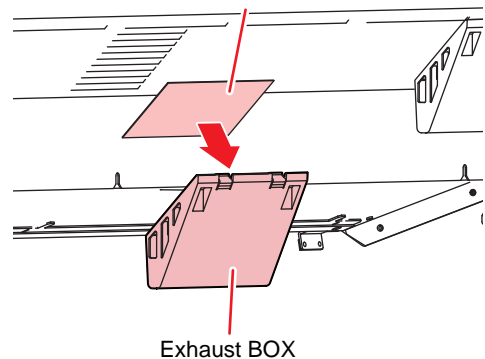

4 Attach the exhaust BOX filter to the exhaust BOX.

- Insert the exhaust BOX filter in the exhaust BOX tabs.

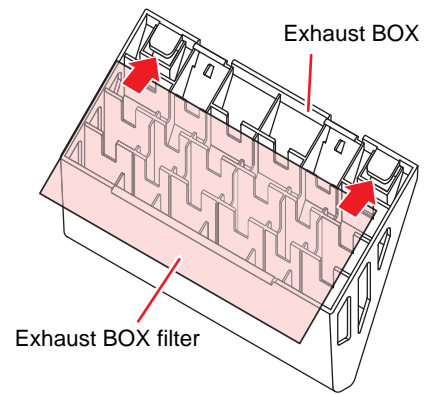

5 Attach the exhaust BOX to its original location.

- Engage the exhaust box rear tabs into the machine body, then push in the front part of the box.

(2) Replace the CP pad set.

Replace CP pad set (SPA-0257) when it is dirty.

1 Push up the tabs (2places) of CP pad Assy.

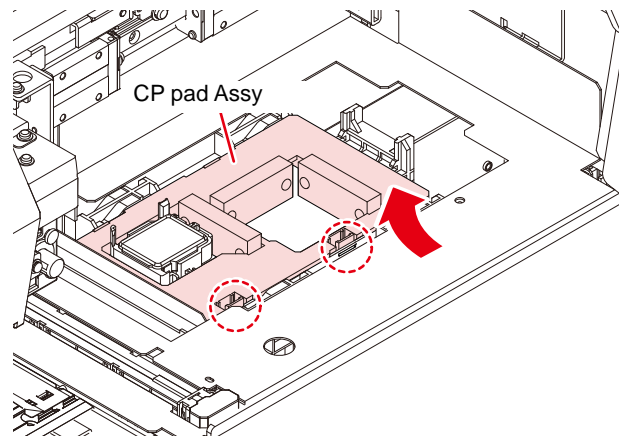

2 Remove the CP pad Assy.

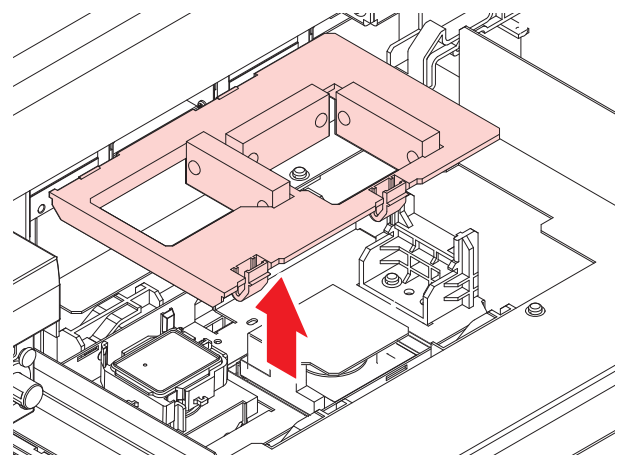

3 Attach a new CP pad Assy.

- After inserting the tabs of CP pad Assy to the slit of C slider, fit the whole.

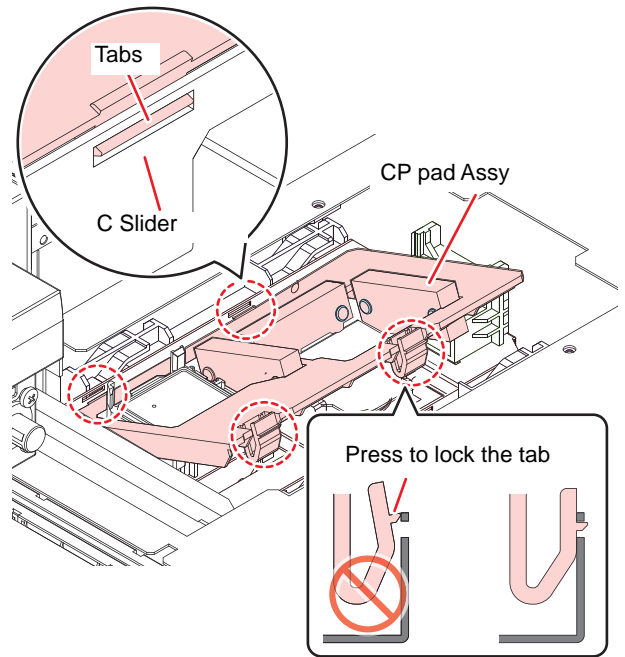

(3) Cleaning or replace the pinch roller.

Cleaning the pinch roller (SPA-0247) when it is dirty. Also replace the pinch roller when it is worn or dirty.

1 Raise the clamp lever to keep the pinch roller lifted.

2 Remove the O-ring retaining the pinch roller.

Important!

- Be careful not to drop the parts in the gap of the device as they are small.

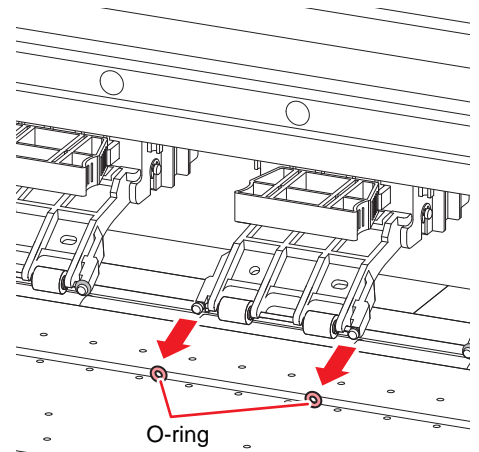

3 Remove the pinch roller.

Important!

- Be careful not to drop the parts in the gap of the device as they are small.

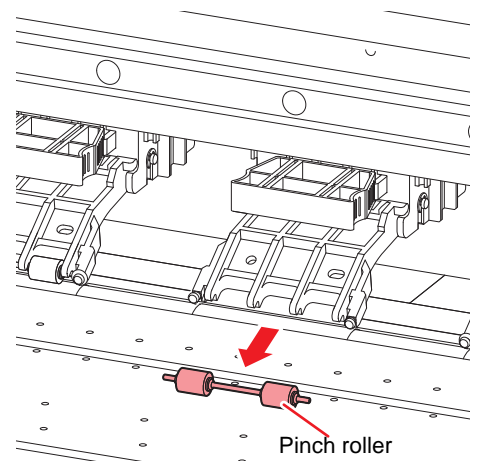

4 Clean the O-ring and pinch roller.

- Wipe off the ink sticking to the O-ring and pinch roller with a clean stick dipped in cleaning solution for maintenance. Wipe off so that cleaning solution for maintenance will not remain.
- Attach a new pinch roller, and reattach a new O-ring to their original position when dirt does not fall even if it cleans it.

11. The examples of defective printing

These following examples indicate improper head (nozzle) firing by dust, which effect printing. Confirm the nozzle condition periodically before or during outputting not to use in such as this condition. The nozzle condition can be confirmed with [test printing] in this plotter. (Operation manual Chapter 2 “Test Printing”)

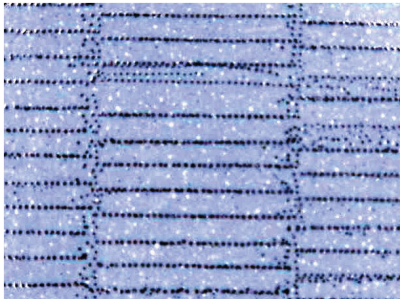

1. Deflection

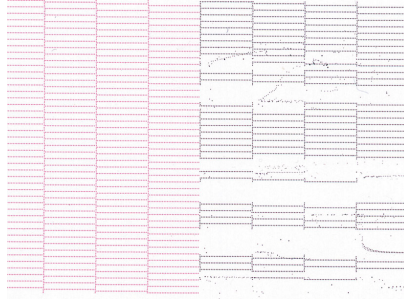

2. Nozzle out



3. Ink dropping



4. Satellite

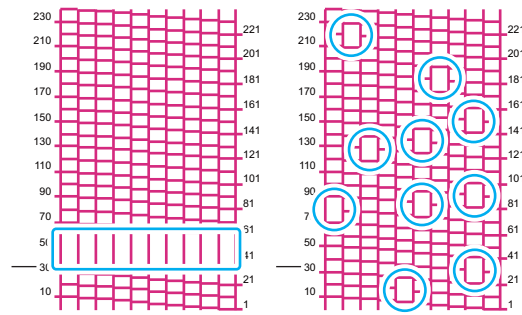

5. Mixing in air

12. Recovery method of defective nozzle discharge

When this printer has not been used for an extended period of time, or depending on the environmental temperature, the discharge at the nozzles could become unstable. In such a case, the following methods may be taken to recover the status of the nozzles.

For symptoms 1 to 4 in P.13 “The examples of defective printing”

1. Daily maintenance and care

- Perform the cleaning of the parts described in this document.

2. Performing Head Cleaning (normal). Refer to Chapter 2 of Operation Manual.

- After having performed the care and maintenance stated in step 1, perform the cleaning of the heads in accordance with the procedures stated in Operation Manual.

Perform test printing and check
(Chapter 2 of Operation Manual)

In the event nozzle missing etc. have not been improved

3. Performing Head Cleaning (hard). Refer to Chapter 2 of Operation Manual.

- If the nozzle missing does not disappear even after repeating the head cleaning (normal) several times, reset the cleaning mode to "hard" and perform the cleaning again.

Perform test printing and check
(Chapter 2 of Operation Manual)

In the event nozzle missing etc. have not been improved

4. Perform the cleaning of the head nozzles. Refer to Chapter 4 of Operation Manual.

- Perform the cleaning of the head nozzles. In this case, leaving time of the cleaning liquid for maintenance shall be made [1 minute].

Perform test printing and check
(Chapter 2 of Operation Manual)

In the event nozzle missing etc. have not been improved

5. Perform the cleaning of the head nozzles again. Refer to Chapter 4 of Operation Manual

- Reset the leaving time of the cleaning liquid for maintenance to [10 minutes], and perform the cleaning of the head nozzles again.

Perform test printing and check
(Chapter 2 of Operation Manual)

Important!

- If the nozzle clogging does not recover after the above operations, contact your local distributor, our sales office, or service center.

13. Supplies

Product Name	Product No.	Product Name	Product No.
Cleaning solution bottle kit A29	SPC-0137	Kimwipe S-200	SPA-0207
Cleaning solution MS2/ES3/HS kit 200	SPC-0369	Wiper cleaner	SPA-0243
Cleaning Stick for Head Surrounding (50 sticks)	SPC-0527	Square waste ink tank 2L	SPA-0246
Male Connector Absorbent for MBIS	SPC-0625	Pinch roller	SPA-0247
MBIS Eco case ASSY	SPC-0626	Exhaust BOX	SPA-0248
3 Inches Paper Tube 130	SPC-0825	Exhaust BOX filter	SPA-0249
3 Inches Paper Tube 160	SPC-0826	Rubber stopper for 2L case	SPA-0250
Media Cutter Blade	SPA-0107	CP pad set 2	SPA-0257
Wiper kit 33S	SPA-0134		



**You can also download the latest manual from our website.
Unauthorized reproduction of any portion of this document is strictly prohibited.**

© 2014 MIMAKI ENGINEERING CO., LTD.

D202690-13-20042022

AT

FW :4.20